

Drum storage device



Fig. 1 TROMBULLY with central point of removal and return stop

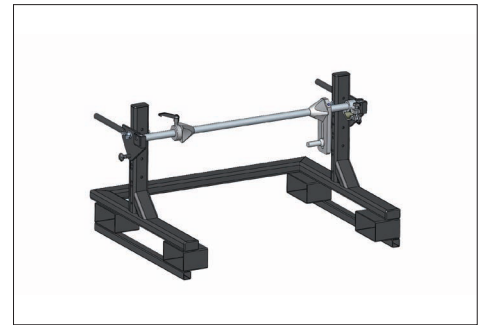

Fig. 2 TROMTRAK 1000 drum storage device

TROMBULLY

The multifunctional TROMBULLY-system is suitable for mechanical pay-off in connection with a motor driven rewind or cutting-to-length machine. It is the ideal system for the manufacturing of cable sets, cable forms or cable looms in the machine construction and pre-assembly area.

This system consists of a frame unit, the size of which can be extended individually. In this frame unit the drum storage devices are installed and fixed by means of a lifting device (not included in the scope of supply). The drum storage devices TROMTRAK 1000 are equipped with the drum on the floor. The drums are slid on the axles and fixed by means of a cone and a clamping screw. An adjustable shoe-type brake avoids the follow-up movement of the drum.

Once the drum storage device TROMTRAK 1000 is mounted in the frame unit, the material to be coiled is passed through the guides and at the outfeed, is pushed through the outfeed rake which serves as guide and additional return stop.

The central cable guiding at the end of the frame unit allows the individual removal of the cables and lines concerned.

It is also possible to remove several cables and lines at the same time.

TROMBULLY

No. of drum pay-outs selectable

Drum-Ø max. 1000 mm

Drum width max. 710 mm

Drum weight max. 250 kg

Arrangement of the spool units max. 4 pcs. on top of one another / max. 15 pcs. behind each other

Cable-Ø max. 20 mm

Advantages

Central cable pay-out

Low drum coast down due to adjustable brake

Space-saving

No displacement of winder or cutting unit necessary

Coil storage device TROMTRAK also usable as single devices

Double-sided equipment possible